



Cent. Eur. J. Energ. Mater. 2017, 14(2): 1-18 (**These page numbers will be altered**);
DOI: 10.22211/cejem/68407

Management of Change as a Part of Caring about Safety

Milos Ferjencik,* Aline Cardoso Anastacio

*Faculty of Chemical Technology, Institute of Energetic Materials,
University of Pardubice*

Studentska 95, CZ53210 Pardubice, Czech Republic

**E-mail: milos.ferjencik@upce.cz*

Abstract: No plant, including those manufacturing explosives or explosive articles, remains unchanged during its lifetime. But it is also known that changes – revisions in the original design – quite often contribute to adverse events. Operators therefore need to know how to manage the modifications safely, not increasing the danger for the operation, its employees or its surroundings. This article describes two accidents in the explosives manufacturing industry that were caused by a deficiency in the management of change. For both cases, a possible way as to how the accidents could have been prevented using proper management of the change procedure, based on risk analysis, is described.

Keywords: accident prevention, risk analysis, LOPA, organizational change

1 Introduction

It is typical and not surprising that in industry an incident occurs just after a change. Section 2 presents one example of such an incident. A procedure is presented in Section 3 that would have been able to prevent the incident. This procedure is based on a simplified form of quantitative risk analysis (for more about quantitative risk analysis see *e.g.* [1]). The LOPA (Layer of Protection Analysis) method that was introduced in [2] and became popular, especially in the US chemical industry, is used for this purpose. The starting point of LOPA is a selection of scenarios. For the sake of brevity, scenarios in this article are selected without detail explanations. Generally they may originate from the application of a hazard identification procedure such as Preliminary Hazard Analysis (PreHA) or Hazard and Operability Studies (HAZOP) (*e.g.* [3]).

Section 4 generalizes the procedure from Section 3. Section 5 provides another example of an accident, this one connected with management of an organizational change. Section 6 illustrates how the second accident could have been prevented using the procedure from Section 4.

2 Example 1: Incident in a Delay Element Production Unit

Delay elements for electric detonators (Figure 1) are manufactured in a building consisting of several rooms. In some of them, dosing and stamping of the delay composition into dosing spoons is performed remotely. People work in the central room, filling the dosing spoons with blank delay elements, manipulating the stamped delay elements, and handling the empty dosing spoons (Figure 2).

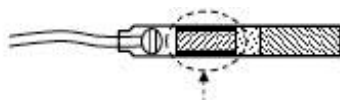

Figure 1. Delay element for detonator

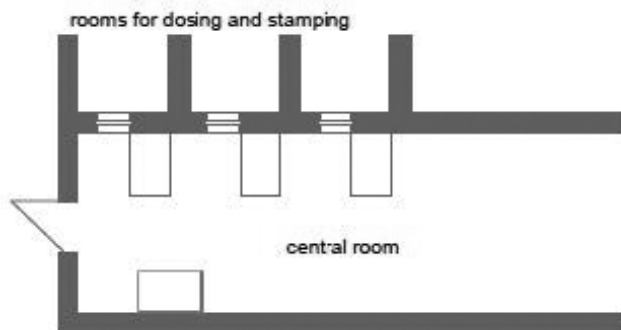

Figure 2. Delay element production unit

Before the change, air in the central room contained toxic and combustible dust. The purpose of the change was to install a ventilation system in order to improve the working conditions in this room (Figure 3).

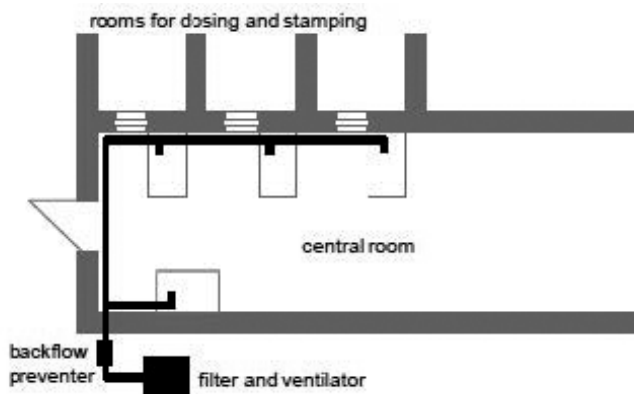

Figure 3. Changes in the delay element production unit

An incident occurred a short time after the production unit had been put into operation again. A spark produced during cleaning of the empty dosing spoon was sucked into the new ventilation system and ignited a fire inside the filter. The omission of the possibility that a spark could penetrate the ventilation system during regular activity in the central room can be identified as a cause of the incident.

3 Example 1: What should have been done to prevent the incident

3.1 Evaluation of the unit before the change

Risk analysis should have been performed and documented for any activity handling explosive substances, prior to the start of operations. The results of the four steps of risk analysis for the building from Figure 2 are shown in the following sections.

3.1.1 Identification of hazards

The presence of a dangerous substance during any activity can be considered to be a hazard. At least the following hazards would have been definitely identified in the production unit:

- 1a:** delay composition in rooms for dosing and stamping,
- 1b:** residues of compacted delay composition in the dosing spoon (when using the ejecting press),
- 1c:** airborne fine dust.

The locations of the above hazards in the building are shown schematically in Figure 4.

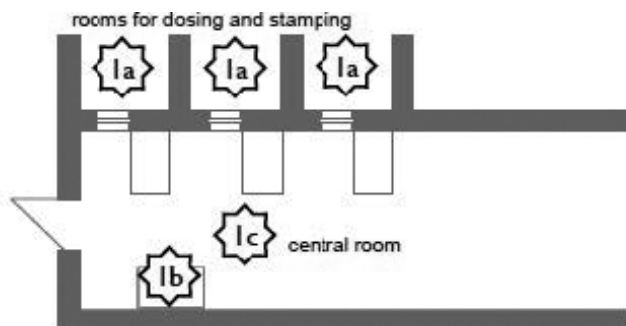

Figure 4. Hazards in the delay element production unit

3.1.2 Description of the incident scenarios

Possible incident scenarios are connected to each of the identified hazards. Scenarios are described according to the conventions from reference [2], as a pair of initiating events – consequence:

- Incident scenarios starting in hazard 1a

1aA1 scenario: burning is initiated in hazard 1a – the effects are confined to the room where the burning was initiated,

1aA2 scenario: burning is initiated in hazard 1a – the effects also cause damage and injuries in the central room.

- Incident scenarios starting in hazard 1b

1bA1 scenario: ignition of residues of compacted delay composition – worker unharmed,

1bA2 scenario: ignition of residues of compacted delay composition – worker is burned.

- Incident scenarios starting in hazard 1c

1cA1 scenario: inhalation of dust – serious illness of a worker.

3.1.3 Identification of critical scenarios

In order to be able to identify critical scenarios, a classification of consequences (Table 1) is introduced. Table 1 represents a modified version of Table 3.2 from [2]. All scenarios with consequences from class III or higher are considered to be critical.

Table 1. Consequence categories

	I Negligible	II Low	III Medium	IV High	V Very High
Personnel	No injury, no lost time	Minor injury, no lost time	Single injury, not severe, possible lost time	One or more severe injuries	Fatality or permanently disabling injury
Community	No injury, hazard or annoyance to public	No injury, hazard or annoyance to public	Odour or noise complaint from the public	One or more minor injuries	One or more severe injuries
Facility	Minor damage costing <USD 10,000, no loss of production	Minor damage costing >USD 10,000, no loss of production	Damage costing >USD 100,000, minimal loss of production	Major damage costing >USD 1 M, some loss of production	Total destruction, cost >USD 10 M, significant loss of production

Scenarios 1aA1, 1aA2, 1bA2, and 1cA1 are critical. In order to prevent/mitigate the scenarios, the following limiting conditions and working rules were used in the activities in the building:

Against scenario 1aA1: conditions and rules that decrease the probability of burning and also that limit the effects of burning, such as the maximum allowed amount of explosives in the room.

Against scenario 1aA2: conditions (attested resistance of wall) that decrease the effects to the central room.

Against scenario 1bA2: working rules (mandatory use of protective tools – leather gloves and apron, face shield) to prevent burning of worker.

Against scenario 1cA1: working rules (mandatory use of respirator) to prevent inhalation of dust.

3.1.4 Evaluation and assessment of the risks of critical scenarios

After evaluation of the consequences and frequencies of the critical scenarios, their risks could be assessed using the risk matrix in Figure 5 (according to [2]). The scenarios that fall into the two uppermost risk zones in the risk matrix are considered to be unacceptable.

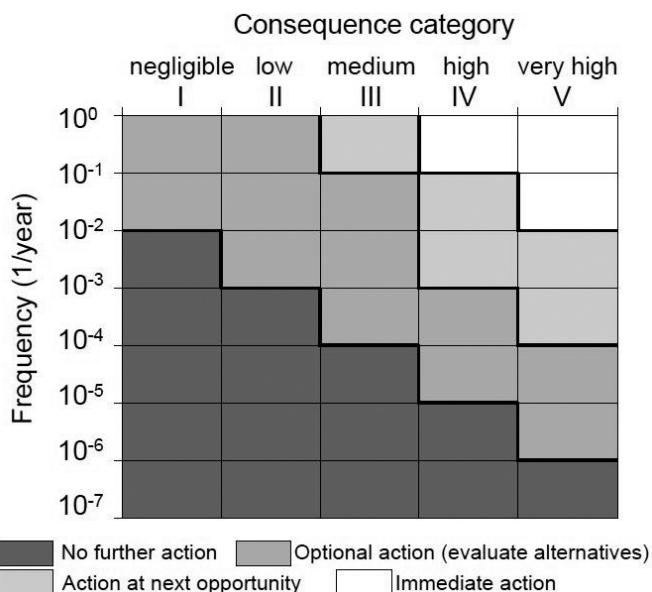

Figure 5. Risk matrix

The evaluation could apply a simplified LOPA method according to [2, 4-6]. Table 2 reproduces the completed LOPA form according to [2] for scenario 1cA1. This table shows how the LOPA form can be used to evaluate those scenarios that have “chronic”, not “acute”, character. Table 3 summarizes important values from the LOPA evaluations for all four critical scenarios. Figure 6 projects the results of the evaluations into the risk matrix. It shows that only the risk of scenario 1cA1 is unacceptable, without any doubt.

Table 2. Completed LOPA form for scenario 1cA1, before the change

Scenario Title: 1cA1	Description: inhalation of dust – serious illness of a worker	Probability	Frequency per year
Consequence Description/ Category	One or more severe injuries/ Category IV		
Risk tolerance criteria			10^{-3}
Initiating event	Employees exposed to long term inhalation		10
Enabling event or condition	Development of illness	0.1	
Conditional modifiers (if applicable)	Probability of ignition	N/A	
	Probability of personnel in affected area	1	
	Probability of fatal injury	N/A	
	Others	N/A	
Frequency of unmitigated consequence			1
Independent protection layers			
BPCS alarm and human action	Use of respirator	0.01	
Pressure relief device			
SIF			
Safeguards (non-IPLs)			
Total PFD for all IPLs		0.01	
Frequency of mitigated consequence			10^{-2}

Table 3. Values from the LOPA evaluations before the change

Scenario Title	1aA1	1aA2	1bA2	1cA1
Initiating event per year	0.1	0.1	10	10
Enabling event or condition	1	1	1	0.1
Conditional modifiers	1	1	0.5	1
Total PFD for all IPLs	1	0.001	0.01	0.01
Frequency of mitigated consequence per year	10^{-1}	10^{-4}	5×10^{-2}	10^{-2}

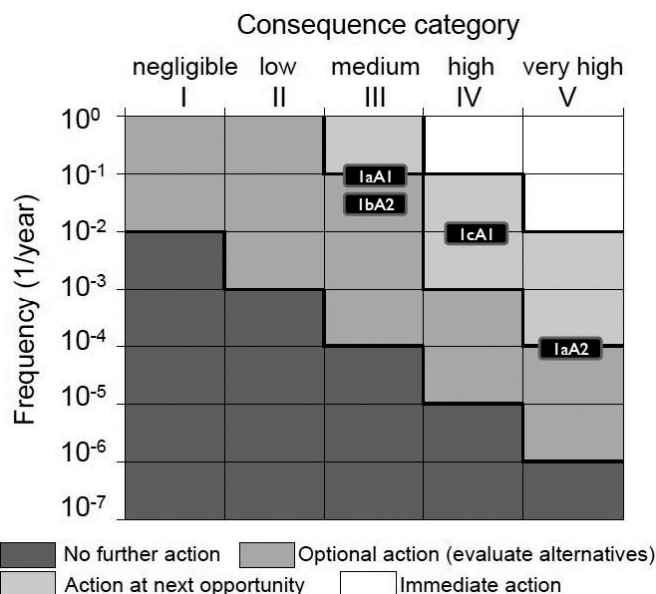

Figure 6. Risk assessment of the delay element production unit before the change

3.2 Evaluation of the unit after the change

The above risk assessment confirms that the objective of the change shown in Figure 3 is correct. Risk associated with the scenario 1cA1 has to be reduced at the next opportunity. A ventilation system with suction at the workplaces in the central chamber and a filter outside the building seems to be a promising idea. Let us evaluate the change of risk associated with the proposed change.

3.2.1 Identify hazards

Hopefully, hazard 1c will be removed as a result of the change. The other two hazards identified before the change will still be present. Installation of an exhaust system adds two new hazards to the building:

1d: fine composition dust trapped in the filter,

1e: fine composition dust deposited on the inner walls of the ventilation piping.

The locations of the new hazards together with the old ones present in the building are shown in Figure 7.

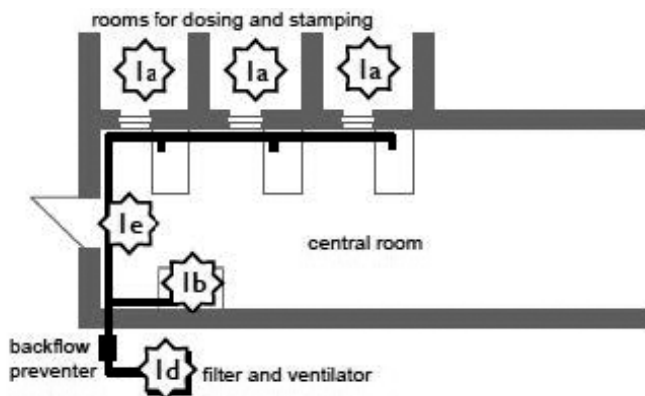

Figure 7. Hazards in the delay element production unit after the change

3.2.2 Description of the incident scenarios

There are three ways in which the set of scenarios from Section 3.1.2 may change: (i) frequencies of known scenarios initiating in old hazards can change, (ii) new scenarios initiated in new hazards may arise, (iii) new scenarios may also be possible to initiate in the old hazards.

(i) Old scenarios in old hazards:

As hazard c1 is removed, scenario 1cA1 is also removed. The frequencies of the other three known critical scenarios in hazards 1a and 1b are expected to remain unchanged.

(ii) New scenarios in new hazards:

- Incident scenarios starting in hazard 1d

1dA1 scenario: burning is initiated in hazard 1d – damage only outside the building,

1dA2 scenario: burning is initiated in hazard 1d – damage and injuries also in the central room.

- Incident scenarios starting in hazard 1e

1eA1 scenario: burning is initiated in hazard 1e – damage only outside the building,

1eA2 scenario: burning is initiated in hazard 1e – damage and injuries also in the central room.

(iii) New scenarios in old hazards

- Incident scenarios starting in hazard 1b

1bB1 scenario: ignition of residues of compacted delay composition – damage outside the building,

1bB2 scenario: ignition of residues of compacted delay composition – damage

and injuries also in the central room.

The latter two scenarios were overlooked when the change was prepared. It is however highly probable that if the analysis were systematic, and possible interactions of the hazards were assessed, scenarios 1bB1 and 1bB2 would have been identified as is shown here.

3.2.3 Identification of critical scenarios

Among the new scenarios, scenarios 1dA1, 1dA2, 1eA1, and 1eA2 are labelled as critical. Also the omitted scenarios 1bB1 and 1bB2 should have been identified as critical.

Limiting conditions and working rules were introduced that decrease the probability of ignition and therefore act against scenarios 1eA1 and 1dA1. Limiting conditions and working rules (installation of backflow preventer) were introduced that prevent the central room being affected and therefore act against scenarios 1eA2 and 1dA2. However, additional conditions were omitted that would have reduced the likelihood of scenarios 1bB1 and 1bB2.

3.2.4 Evaluation and assessment of the risks of the critical scenarios

Table 4 summarizes the important values from the LOPA evaluation for all five critical scenarios. The results are then projected into the risk matrix (Figure 8). If this evaluation had been made, it would have been concluded that the change was unacceptable. Critical scenarios 1bB1 and 1bB2 represent an unacceptable risk.

The incident described in Section 2 corresponds to the omitted unacceptable scenario 1bB1.

Table 4. Values from LOPA evaluations after the change, new scenarios

Scenario Title	1dA1	1dA2	1eA1	1eA2	1bB1	1bB2
Initiating event per year	0.06	0.06	0.1	0.1	10	10
Enabling event or condition	1	1	0.1	0.1	1	1
Conditional modifiers	1	1	1	1	0.1	0.1
Total PFD for all IPLs	1	0.01	1	0.01	1	0.01
Frequency of Mitigated Consequence per year	6×10^{-2}	6×10^{-4}	10^{-2}	10^{-4}	1	10^{-2}

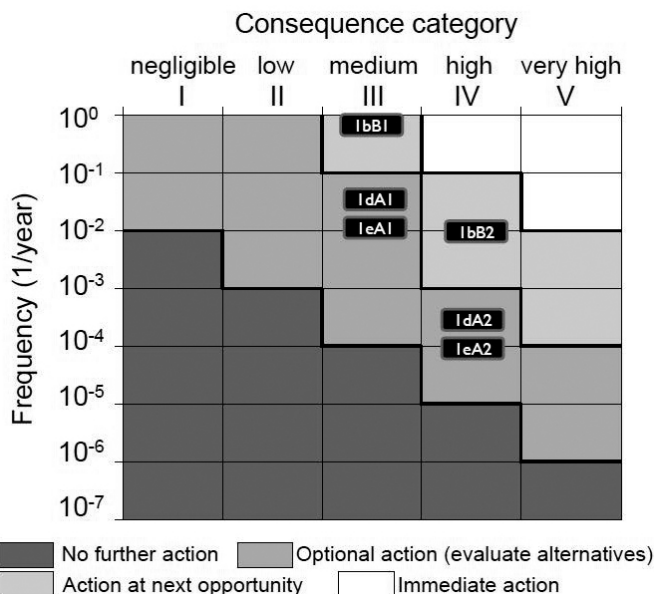

Figure 8. Risk assessment of the delay element production unit after the change, with new scenarios

4 General Procedure for Management of Change Based on Risk Analysis

The purpose of change management is to ensure the changes do not increase the risk. As Example 1 shows, the risk may be increased due to the introduction of new hazards, or by increasing the risk from known hazards. Guidelines [7] and [8] state that change management shall:

- A: Identify and classify the change
- B: Evaluate the change
- C: Approve the change
- D: Communicate the change
- E: Ensure closure and follow-up

Example 1 describes in detail how step B, evaluation of change, should be performed. Step B can be further divided into the following four sub-steps:

- B.1: Identify the hazards
- B.2: Describe the incident scenarios
- B.3: Identify the critical scenarios

- B.4: Evaluate and assess the risk of critical scenarios

The application of such a management of change procedure based on risk analysis is strongly recommended by the authors. Example 1 shows that the LOPA risk analysis method may be helpful within the procedure and illustrates that such a procedure may help to avoid dangerous omissions when applied to a process that is to be physically modified.

5 Example 2: Incident in a concentrated nitric acid storage facility

A storage tank that supplies a nitration process consists of several interconnected nitric acid tanks, one receiving nitric acid 98% from a truck tank, as shown in Figure 9.

On the day before the incident, valve v1 did not open when required, and it was necessary to remove it for maintenance. In order to do so, flange f1 needed to be opened. The written maintenance procedure states that a plant operator must verify that the pipe line is empty and flush it with water, before calling upon the maintenance team. Also, all maintenance shall be supervised by a plant operator.

This industrial facility is actually a complex of several plants, not all dealing with such strong acids. About four years before the accident, maintenance professionals were allocated for each plant. However, budget cuts led to reduced staff, retired workers were not replaced, and all of the different plants started to share the same centralized maintenance employees. Two years after that, the number of plant operators also shrank for the same reasons. The organizational structure changed, but no documented and systematic analysis of the safety effects of downsizing was done.

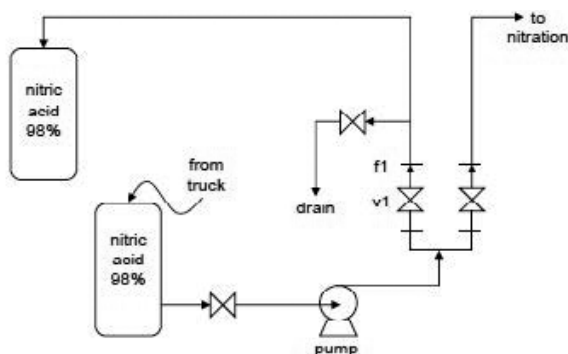

Figure 9. Nitric acid storage facility

Due to these changes, a maintenance worker with no experience of the nitric acid facility was sent to open the flange f1. He did not know the procedure. At the same time, the plant operator did not provide him with the support expected by the procedure. During flange opening, a solution of nitric acid (mixed with some water) in the upper part of the pipe formed a jet that splashed into the operative's body and face. The worker was not using the full face protection or an anti-acid suit. He used only goggles and a regular uniform protecting him only against acid drops. About half of his body was acid-burned.

6 Example 2: What should have been done to prevent the incident

General procedure for management of change from Section 4 is followed in the text below.

6.1 Evaluation of the unit before the change

In this case, the risk analysis is not applied to the plant operation but to the maintenance actions performed. Namely, the analysis is focused on the maintenance procedure for valve v1 removal.

6.1.1 Identification of the hazards

At least the following hazard should have been definitely identified in the facility: 2a: nitric acid inside the piping above flange f1.

Location of the above hazard in the facility is shown in Figure 10.

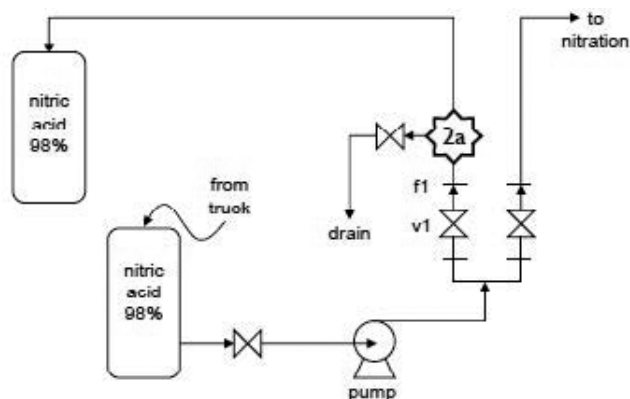

Figure 10. Selected hazard in nitric acid storage facility

6.1.2 Description of the incident scenarios

The following scenario starting in hazard 2a should have been evaluated:

2aA1 scenario: valve v1 removal is required – maintenance person splashed by the nitric acid.

6.1.3 Identification of the critical scenarios

Scenario 2aA1 is labelled as critical – its consequences fall into consequence category V.

Working rules that act against the scenario encompass emptying (decontamination) of the pipeline by the plant operator, checking by the maintenance person that the pipeline is empty, and wearing of full-body protective equipment during work. Moreover, work is to be supervised by the plant operator.

6.1.4 Evaluation and assessment of the risks of the critical scenarios

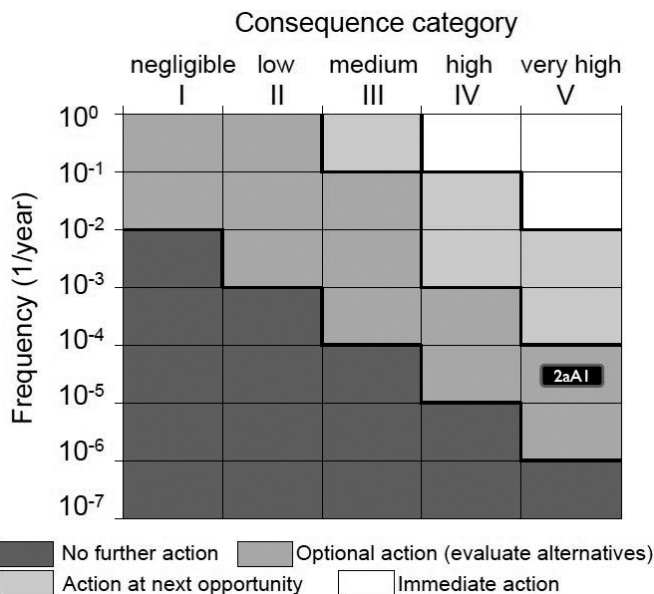

Figure 11. Risk assessment of the nitric acid facility before the change

Again, the evaluation could use the LOPA method according to [2, 4-6]. The LOPA form for the critical scenario is completed in Table 5. At least one plant operator and a maintenance person are supposed to co-operate in accordance with the written maintenance procedure. The possibility that the maintenance person would be exposed to nitric acid is decreased by enabling condition probability

0.01, since the plant operator is trained to empty the pipeline when removal of valve v1 is required. The maintenance person is trained to work in full-body protection, according to the procedure, and under the supervision of the plant operator. The probability of failure on demand for this layer of protection can be a mere 0.001 [6].

The evaluation from Table 5 is projected into the risk matrix as shown in Figure 11, indicating that the risk of scenario 2aA1 is acceptable. But this conclusion is delicate. This favourable result can be expected only if both adherence to the written maintenance procedure and independent supervision can be presumed.

Table 5. Completed LOPA form for scenario 2aA1, before the change

Scenario Title: 2aA1	Description: valve v1 removal is required – maintenance person splashed by the nitric acid	Probability	Frequency per year
Consequence description/ Category	Fatality or permanently disabling injury/ Category V		
Risk Tolerance Criteria			10^{-4}
Initiating event			5
Enabling event or condition	Plant operator forgets to empty the line	0.01	
Conditional modifiers (if applicable)	Probability of ignition	N/A	
	Probability of personnel in affected area	1	
	Probability of fatal injury	N/A	
	Others	N/A	
Frequency of unmitigated consequence			0.05
Independent protection layers			
BPCS alarm and human action	Use of full body protection	0.001	
Pressure relief device			
SIF			
Safeguards (non-IPLs)	supervision by plant operator, awareness by maintenance person		
Total PFD for all IPLs		0.001	
Frequency of mitigated consequence			5×10^{-5}

6.2 Evaluation of the unit after the change

6.2.1 Identification and classification of the change, evaluation of the change

In the case of Example 2 the change was not physical. One position (specialist maintenance person) was terminated and replaced by a new one (general purpose maintenance person), with a smaller total number of personnel. It is an organizational change, similar to changes of individual personnel, number of employees, shifts, and work places according to [9].

It is not easy to determine the safety effects of organizational changes. A practical option may be to use checklists. Comparison with a proper checklist may help to identify the adverse effects resulting from a change. In this analysis, tables in appendix B.2 in [10] were used. Table 6 shows only those aspects of change that would reduce safety (and adversely influence scenario 2aA1).

Table 6. Check list to evaluate an organizational change

Could the change require changes in ...	Yes/ No/ NA	Possible effect	Action to maintain or improve safety
Process Safety Management programs for training?	Yes	Maintenance person is not necessarily included in training for all areas.	Include all maintenance employees in safety training for all areas.
Procedures or personnel involved in removing equipment from service or preparing it for maintenance?	Yes	Personnel would be required to perform any task. Supervisors can no longer be present in all preparation procedures.	Maintenance personnel should be aware of all of the required preparation for all areas work.

6.2.2 Identification of the hazards and description of the incident critical scenarios

Hazard, critical scenario, and conditions against the scenario are the same as before the change.

6.2.3 Evaluation and assessment of the risks of critical scenarios

If the maintenance person is poorly trained and the plant operator overloaded, less favourable values have to be used in the LOPA analysis in Table 5. Stress in the operator's work will increase the probability of the enabling condition,

supposedly by a factor of 10. In the case that the maintenance person is poorly trained, and the task is new for them, the probability of a failure on demand close to 1 can be attributed to protective human action according to [6]. In any case it is clear, that after the change the risk of scenario 2aA1 moves to the unacceptable area of the risk matrix.

7 Conclusions

It is impossible to completely avoid accidents. However the application of the procedure described may help to reduce the risk. Examples show that even the simple risk analysis method LOPA is a satisfactorily sophisticated tool on which the management of change in the explosives manufacturing industry can be based.

LOPA has the potential – as in Example 1 – to inspire the identification of particular accident scenarios which accompany physical modification of the process and which would otherwise not be recognised. LOPA gives – as in Example 2 – a timely warning that a “mere” organizational change can convert a delicate interplay of human actions into an unacceptably risky activity.

Systematic application of management of change procedures based on risk analysis represents one of the activities that make a difference between less and more effective forms of caring about safety.

References

- [1] Ferjencik, M. The Quantitative Risk Assessment of Civil Facilities Handling Explosives. *New Trends Res. Energ. Mater., Proc. Semin., 11th*, Pardubice, Czech Republic **2008**, 140-149.
- [2] *Layer of Protection Analysis: Simplified Process Risk Analysis*, Center for Chemical Process Safety (CCPS), American Institute of Chemical Engineers. New York **2001**.
- [3] *Guidelines for Hazard Evaluation Procedures*. 3rd ed., Center for Chemical Process Safety (CCPS), Wiley, Hoboken **2008**.
- [4] *Guidelines for Initiating Events and Independent Protection Layers in Layer of Protection Analysis*. Center for Chemical Process Safety (CCPS), Wiley, Hoboken **2015**.
- [5] *Guidelines for Enabling Conditions and Conditional Modifiers in Layer of Protection Analysis*. Center for Chemical Process Safety (CCPS), Wiley, Hoboken **2014**.
- [6] Schmidt, M. S. Villains, Victims, and Heroes: Accounting for the Roles Human Activity Plays in LOPA Scenarios. *J. Loss Prev. Process Ind.* **2014**, 30: 256-262.

- [7] *Guidelines for Risk Based Process Safety*. Center for Chemical Process Safety (CCPS), American Institute of Chemical Engineers, New York **2007**.
- [8] *Guidelines for Management of Change for Process Safety*. Center for Chemical Process Safety (CCPS), Wiley, Hoboken **2008**.
- [9] Wincek, J.; Sousa, L.; Myers, M.; Ozogc, H. Organizational Change Management for Process Safety. *Process Saf. Prog.* **2015**, *34*(1): 89-93.
- [10] *Guidelines for Managing Process Safety Risks During Organizational Change*. Center for Chemical Process Safety (CCPS), Wiley, New York **2013**.